

Magic series MPPT Solar Controller

12/24V, 10/20/30/40A,
130/200/260/390/520/780W/1KW

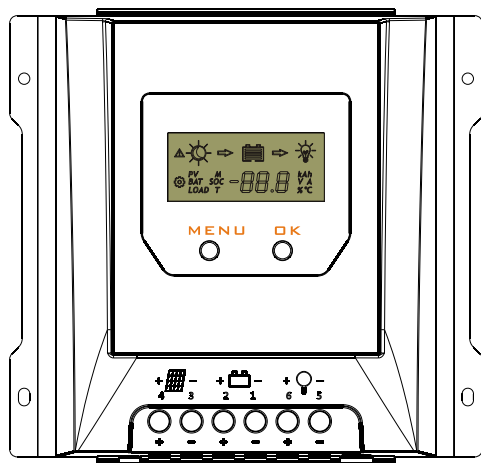

User Manual

User Manual_Magic series_IA
CE, Rohs, ISO9001:2015
Subject to change without notice!

Contents

1.Safety instructions and waiver of liability	2
1.1Safety Instructions	
1.2Liability Exclusion	
2.Product Overview	3
2.1Outstanding Features	
2.2MPPT	3
2.3Four Charging Stage	5
3.Dimensions	6
3.1 The dimensions of MT1050/1550-EU	
3.2 The dimensions of MT2075/2010/3075.....	7
3.3 The dimensions of MT3010/4010.....	8
4.Structure & Accessory	9
4.1Structure & Characteristics of MT1050/1550-EU	
4.2Structure & Characteristics of MT2075/2010/3075	
4.3Structure & Characteristics of MT3010/4010.....	10
4.4Optional Accessories	
5.Installation	11
5.1Installation Notes	
5.2Mounting Location Requirements	
5.3Connection.....	12
5.4Grounding	
6.Operation	13
6.1LCD Display	
6.1.1Status Description	
6.1.2The interface automatically cycles.....	14
6.1.3 Press OK to browse the interface	
6.1.4Fault indication.....	15
6.2Key function	
6.3USB interface	
6.4Parameters setting.....	16
6.4.1Low voltage protection and reconnect	
6.4.2Battery type	
6.4.3Load mode	
7.Protections, Troubleshooting and Maintenance	17
7.1 Protection	
7.2Troubleshooting.....	18
7.3 Maintenance	
8.Technical Data	19
8.1 Technical data of MT1050/1550-EU/MT2075/MT3075	
8.2 Technical data of MT2010/MT3010/MT4010.....	20

Dear Clients,

Thanks for selecting the Magic series solar controller.

Please take the time to read this user manual, this will help you to make full use of many advantages the controller can provide your solar system.

This manual gives important recommendations for installing and using and so on. Read it carefully in your own interest and pay attention to the safety recommendations in it please.

1, Safety instructions and waiver of liability

1.1 Safety Instructions

The following symbols are used throughout this manual to indicate potentially dangerous conditions or mark important safety instructions. Please take care when meeting these symbols.



WARNING: Indicates a potentially dangerous condition. Use extreme caution when performing this task.



CAUTION: Indicates a critical procedure for safe and proper operation of the controller.



CAUTION:

- 1) There are no user serviceable parts inside the controller. Do not disassemble or attempt to repair the controller.
- 2) Keep children away from batteries and the charge controller.

1.2 Liability Exclusion

The manufacturer shall not be liable for damages, especially on the battery, caused by use other than as intended or as mentioned in this manual or if the recommendations of the battery manufacturer are neglected. The manufacturer shall not be liable if there has been service or repair carried out by any unauthorized person, unusual use, wrong installation, or bad system design.

2, Overview

Magic series solar controller is based on an advanced maximum power point tracking (MPPT) technology developed, dedicated to the solar system, the controller conversion efficiency up to 97%.

2.1 It comes with a number of outstanding features, such as:

- Innovative Max Power Point Tracking(MPPT) technology, tracking efficiency >99%
- Full digital technology, high charge conversion efficiency up to 98%
- LCD display design, read operating data and working condition easily.
- Real-time energy statistics function.
- 12V/24V automatic recognition
- AGM、Liquid and GEL battery for selection
- External temperature sensor, automatic temperature compensation
- Built-in temperature sensor, when the temperature exceeds the set value, the charging current will lower down followed by the decrease of temperature, so as to control the controller' s temperature rise
- Four stages charge way: MPPT, boost, equalization, float
- With current-limiting charging mode, when the power of solar panel is over-sized and charging current exceeds the rated current, the controller will lower the charging power, which enables the system to work under the rated charging current
- Multiple load control modes: Standard, Dusk to Dawn, Timer and User-defined mode.
- Two USB interfaces(EU Series)
- Based RS-485 standard Modbus protocol, to maximize their communication needs of different occasions.
- Perfect EMC & thermal design
- Full automatic electronic protect function

2.2 MPPT

MPPT profile

The full name of the MPPT is maximum power point tracking. It is an advanced charging way which could detect the real-time power of the solar Module and the maximum point of the I-V curve that make the highest battery charging efficiency.

Current Boost

Under most conditions, MPPT technology will "boost" the solar charge current.

MPPT Charging: Power Into the controller (**P_{max}**)=Power out of the controller (**P_{out}**)

$$I_{in} \times V_{mp} = I_{out} \times V_{out}$$

* Assuming 100% efficiency. Actually, the losses in wiring and conversion exist.

If the solar module's maximum power voltage (V_{mp}) is greater than the battery voltage, it follows that the battery current must be proportionally greater than the solar input current so that input and output power are balanced. The greater the difference between the V_{mp} and battery voltage, the greater the current boost. Current boost can be substantial in systems where the solar array is of a higher nominal voltage than the battery as described in the next section.

High Voltage Strings and Grid-Tie Modules

Another benefit of MPPT technology is the ability to charge batteries with solar arrays of higher nominal voltages. For example, a 12 Volt battery bank may be charged with a 12-, 24-, 36-, or 48-Volt nominal off-grid solar array. Grid-tie solar modules may also be used as long as the solar array open circuit voltage (Voc) rating will not exceed the maximum input voltage rating at worst-case (coldest) module temperature. The solar module documentation should provide Voc vs. temperature data. Higher solar input voltage results in lower solar input current for a given input power. High voltage solar input strings allow for smaller gauge solar wiring. This is especially helpful and economical for systems with long wiring runs between the controller and the solar array.

An Advantage Over Traditional Controllers

Traditional controllers connect the solar module directly to the battery when recharging. This requires that the solar module operate in a voltage range that is usually below the module's V_{mp} . In a 12 Volt system for example, the battery voltage may range from 10.8-15 Vdc, but the module's V_{mp} is typically around 16 or 17V.

Because traditional controllers do not always operate at the V_{mp} of the solar array, energy is wasted that could otherwise be used to charge the battery and power system loads. The greater the difference between battery voltage and the V_{mp} of the module, the more energy is wasted.

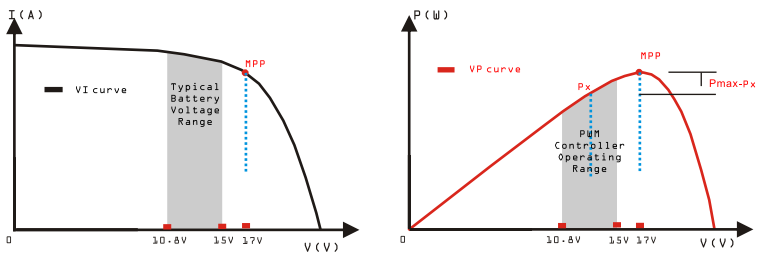

Nominal 12 Volt Solar Module I-V curve and output power graph.

Contrast with the traditional PWM controller, MPPT controller could play a maximum power of the solar panel so that a larger charging current could be supplied. Generally speaking, the MPPT controller's energy utilization efficiency is 15%~20% higher than PWM controller.

Conditions That Limit the Effectiveness of MPPT

The V_{mp} of a solar module decreases as the temperature of the module increases. In very hot weather, the V_{mp} may be close or even less than battery voltage. In this situation, there will be very little or no MPPT gain compared to traditional controllers. However, systems with modules of higher nominal voltage than the battery bank will always have an array V_{mp} greater than battery voltage. Additionally, the savings in wiring due to reduced solar current make MPPT worthwhile even in hot climates.

2.3 MPPT—Four Charging Stage

Magic series controller has a 4-stage battery charging algorithm for rapid, efficient, and safe battery charging.

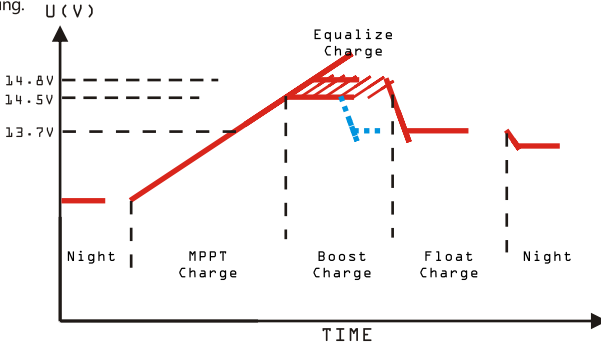

MPPT Charge

In this stage, the battery voltage has not yet reached boost voltage and 100% of available solar power is used to recharge the battery.

Boost Charge

When the battery has recharged to the Boost voltage setpoint, constant-voltage regulation is used to prevent heating and excessive battery gassing. The Boost stage remains 120 minutes and then goes to Float Charge. Every time when the controller is powered on, if it detects neither over discharged nor overvoltage, the charging will enter into boost charging stage.

Float Charge

After the Boost voltage stage, the controller will reduce the battery voltage to Float voltage setpoint. When the battery is fully recharged, there will be no more chemical reactions and all the charge current transmits into heat and gas at this time. Then the controller reduces the voltage to the floating stage, charging with a smaller voltage and current. It will reduce the temperature of battery and prevent the gassing, also charging the battery slightly at the same time. The purpose of Float stage is to offset the power consumption caused by self consumption and small loads in the whole system, while maintaining full battery storage capacity.

In Float stage, loads can continue to draw power from the battery. In the event that the system load(s) exceed the solar charge current, the controller will no longer be able to maintain the battery at the Float setpoint. Should the battery voltage remains below the boost reconnect charging voltage, the controller will exit Float stage and return to Bulk charging.

Equalize Charge

Certain types of batteries benefit from periodic equalizing charge, which can stir the electrolyte, balance battery voltage and complete chemical reaction. Equalizing charge increases the battery voltage, higher than the standard complement voltage, which gasifies the battery electrolyte. If it detects that the battery is being over discharged, the solar controller will automatically turn the battery to equalization charging stage, and the equalization charging will be 120mins. Equalizing charge and boost charge are not carried out constantly in a full charge process to avoid too much gas precipitation or overheating of battery.



WARNING: Risk of explosion!

Equalizing flooded battery can produce explosive gases, so well ventilation of battery box is necessary.

3, Dimensions

3.1 The dimensions of MT1050/1550-EU

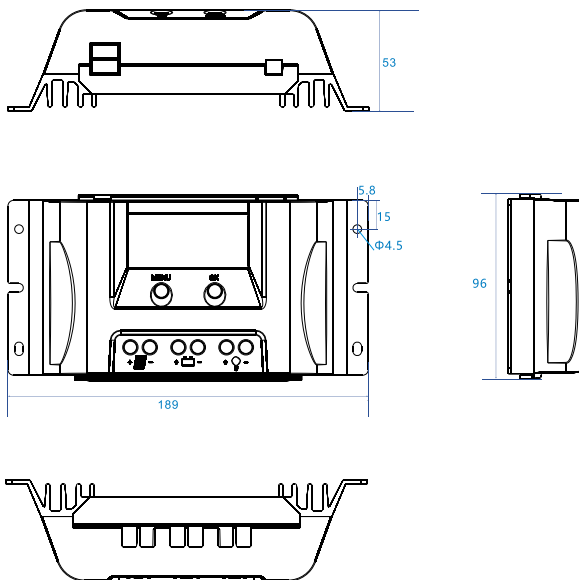

3.2 The dimensions of MT2075/2010/3075

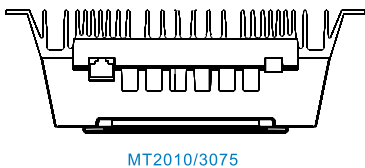
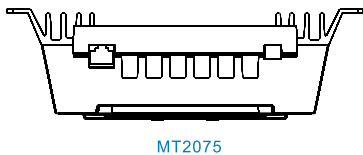
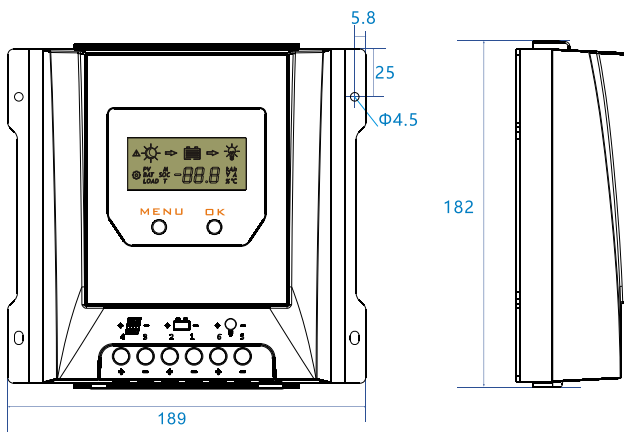
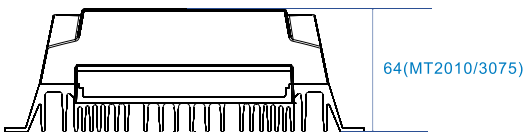
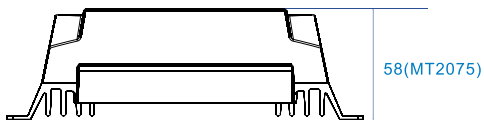

3.3 The dimensions of MT3010/4010

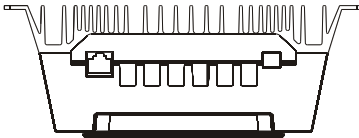
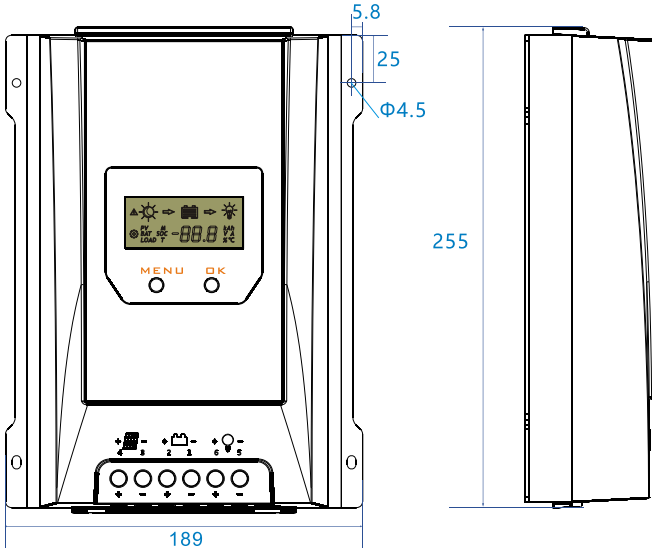
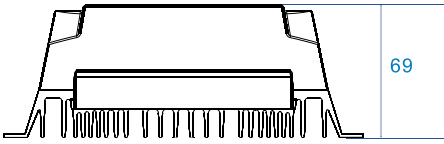

4, Structure & Accessory

4.1 Structure & Characteristics of MT1050/1550-EU

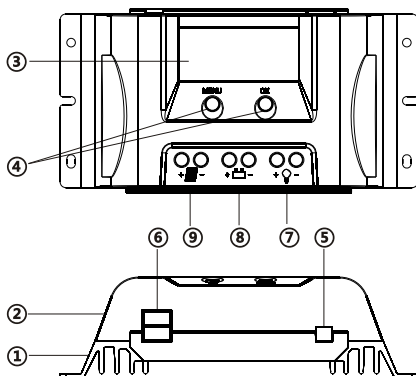

- ①Heat Sink
—dissipate controller heat
- ②Plastic Case
—Internal protection
- ③LCD
—Display settings and operating status, system parameters
- ④Key: MENU、OK
Set and view the operating parameters
- ⑤Temperature Sensor Port
—Collect temperature information, Temperature compensation.
- ⑥Two USB interfaces
—Output 5V, 2A
- ⑦ Load Terminals
—Connected load.
- ⑧Battery Terminals
—Connect the battery.
- ⑨Solar module terminals
—Connected solar modules.

4.2 Structure & Characteristics of MT2075/2010/3075

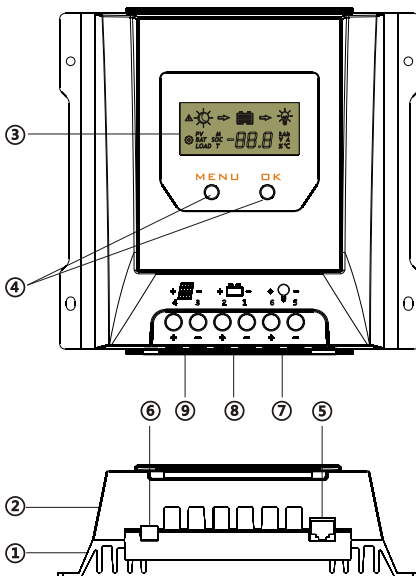

- ①Heat Sink
—dissipate controller heat
- ②Plastic Case
—Internal protection
- ③LCD
—Display settings and operating status, system parameters
- ④Key: MENU、OK
Set and view the operating parameters
- ⑤RJ11 interface
—Connecting monitoring devices
- ⑥Temperature Sensor Port
—Collect temperature information, Temperature compensation.
- ⑦ Load Terminals
—Connected load.
- ⑧Battery Terminals
—Connect the battery.
- ⑨Solar module terminals
—Connected solar modules.

4.3 Structure & Characteristics of MT3010/4010

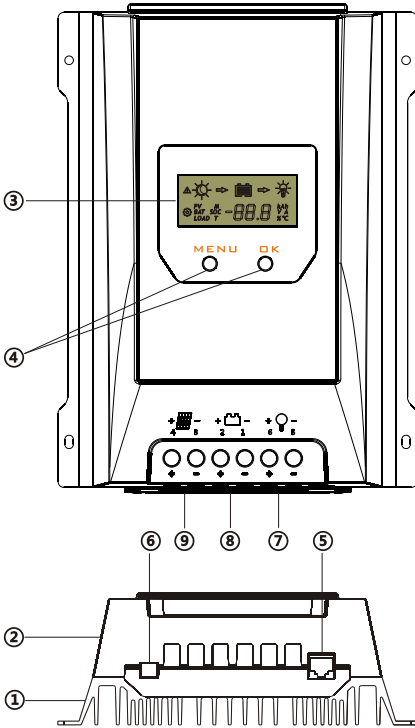

- ①Heat Sink
—dissipate controller heat
- ②Plastic Case
—Internal protection
- ③LCD
—Display settings and operating status, system parameters
- ④Key: MENU、OK
Set and view the operating parameters
- ⑤RJ11 interface
—Connecting monitoring devices
- ⑥Temperature Sensor Port
—Collect temperature information, Temperature compensation.
- ⑦ Load Terminals
—Connected load.
- ⑧Battery Terminals
—Connect the battery.
- ⑨Solar module terminals
—Connected solar modules.

4.4 Temperature Sensor

To collect battery temperature data for temperature compensation so the controller can charge the battery. The temperature sensor connected via interface 6.

If the external temperature sensor is not connected or damaged, the default environment temperature of the controller is 25°C, and the temperature compensation is not carried out when charging.

5, Installation



CAUTION: Please read all instructions and precautions in the manual before installing!
It is recommended to remove the acrylic protective film covering the LCD screen before installation.

5.1 Installation Notes

(1)The solar charge controller may only be used in PV systems in accordance with this user manual and the specifications of other modules manufacturers. No energy source other than a solar generator may be connected to the solar charge controller.

(2)Before wiring installation and adjustment of controller, Always disconnect the solar modules and insurance or circuit breaker of battery terminal.

(3)Only to comply with the range of the battery charge controller.

(4)Batteries store a large amount of energy, never short circuit a battery under all circumstances. We strongly recommend connecting a fuse directly to the battery to avoid any short circuit at the battery wiring.

(5)Batteries can produce flammable gases. Avoid making sparks, using fire or any naked flame. Make sure that the battery room is ventilated.

(6)Uses insulated tools and avoid placing metal objects near the batteries.

(7)Be very careful when working with batteries. Wear eye protection. Have fresh water available to wash and clean any contact with battery acid.

(8)Avoid touching or short circuiting wires or terminals. Be aware that the voltages on special terminals or wires can be as much as twice the battery voltage. Use isolated tools, stand on dry ground, and keep your hands dry.

(9)Prevent water from entering the internal controller, outdoor installation should avoid direct sunlight and rain penetration.

(10)After installation check that all connections are tight line, avoid heat accumulation caused by virtual access danger.

5.2 Mounting Location Requirements

Do not mount the solar charge controller outdoors or in wet rooms. Do not subject the solar charge controller to direct sunshine or other sources of heat. Protect the solar charge controller from dirt and moisture. Mount upright on the wall on a non-flammable substrate. Maintain a minimum clearance of 15cm below and around the device to ensure unhindered air circulation. Mount the solar charge controller as close as possible to the batteries.

Mark the position of the solar charge controller fastening holes on the wall, drill 4 holes and insert dowels, fasten the solar charge controller to the wall with the cable openings facing downwards.

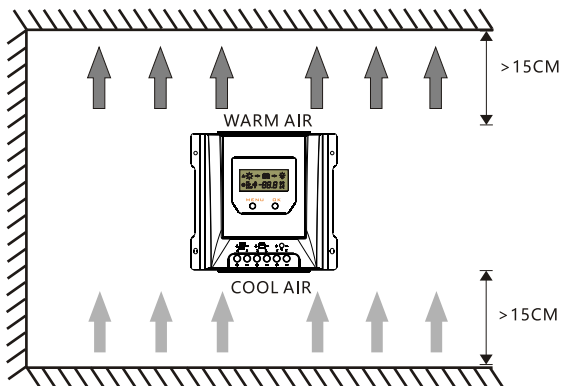

5.3 Connection

We strongly recommend connecting a fuse directly to the battery to protect any short circuit at the battery wiring. Solar PV modules create current whenever light strikes them. The current created varies with the light intensity, but even in the case of low levels of light, full voltage is given by the modules. So, protect the solar modules from incident light during installation. Never touch uninsulated cable ends, use only insulated tools, and make sure that the wire diameter is in accordance with the expected currents of solar charge controller. Connections must always be made in the sequence described below.

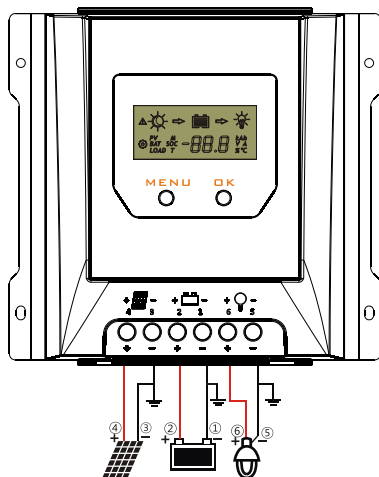

1st step: Connect the battery

Connect the battery connection cable with the correct polarity to the middle pair of terminals on the solar charge controller (with the battery symbol). If the system is 12V, please make sure that the battery voltage is within 10V~15V, else if the system is 24V, the battery voltage should be between 20V~30V. If the polarity is correct, the LCD on the controller will begin to show.

2nd step: Connect the solar module

Ensure that the solar module is protected from incident light. Ensure that the solar module does not exceed the maximum permissible input current. Connect the solar module connection cable to the correct polarity of the left pair of terminals on the solar charge controller (with the solar module symbol).

3rd step: Connect loads

Connect the load cable to the correct polarity of the right pair of terminals on the solar charge controller (with the lamp symbol). To avoid any voltage on the wires, please connect the wire to the load before connect to the controller.

4th step: Final work

Tighten all cables connected to the controller and remove all the debris around the controller (leaving a space of approx. 15 cm).

5.4 Grounding

Be aware that the negative terminals of Magic are connected together and therefore have the same electrical potential. If any grounding is required, always do this on the negative wires.

6, Operation

6.1 LCD Display

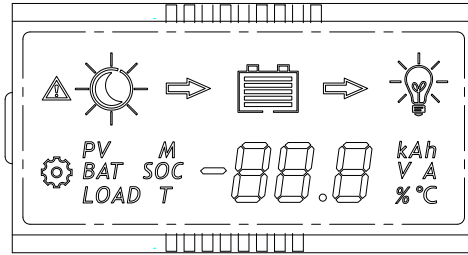

6.1.1 Status Description

Item	Icon	Status
PV array		Daytime, not charging
		Daytime, charging
		Night
	<i>PV</i>	PV voltage, current and ampere hours
	<i>PV T</i>	The total charge ampere hours of the solar panel
Battery		Battery capacity
	<i>BAT</i>	Battery voltage(Programmable)
	<i>BAT</i>	Battery current
	<i>BAT SOC</i>	Battery capacity
	<i>25 °C</i>	Temperature
	<i>BAT T GEL</i>	Battery type(Programmable)
Load	<i>LOAD</i>	Load voltage, current and ampere hours(24H cycle)
	<i>LOAD T</i>	The total discharge ampere hours of the load
	<i>LOAD M</i>	Load mode(Programmable)
		The load is on
		The load is off

PV array charge ampere hours and load ampere hours are off after power failure.



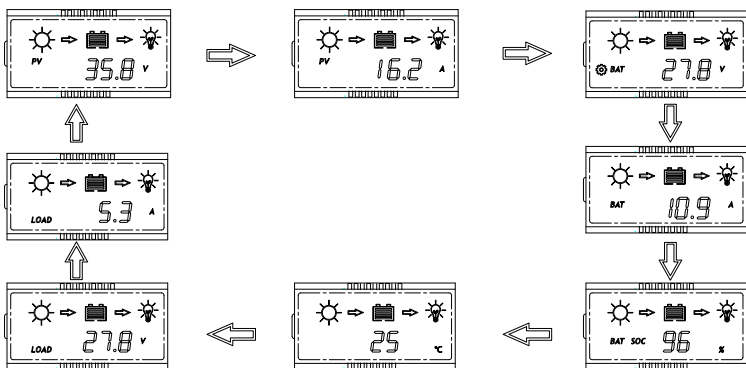

6.1.2 The interface automatically cycles

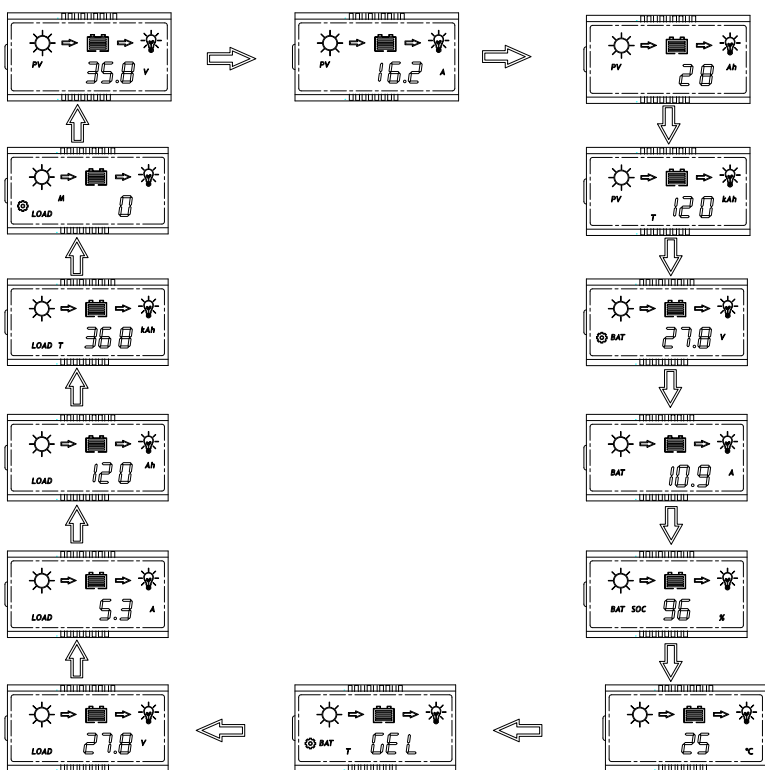

6.1.3 Press OK to browse the interface



6.1.4 Fault indication

Status	Icon	Description
Short circuit	 E1	Load off, fault icon display, load icon flashes, the LCD screen displays E1
Over current	 E2	Load off, fault icon display, load icon flashes, the LCD screen displays E2
Low voltage	 E3	Battery level shows empty, fault icon display, battery frame flashes, the LCD screen displays E3
Over voltage	 E4	Battery level shows full, fault icon display, battery frame flashes, the LCD screen displays E4
Over temperature	 E5	The charge and discharge are off, fault icon display, icon °C flashing, the LCD screen displays E5

6.2 Key function



Mode	Operating
Browse interface	Short press OK
Static display	Press the MENU and OK key at the same time for 1s, the LCD screen will lock the interface. Press the MENU and OK key again for 1s, the LCD interface will unlock and start scrolling.
Setting parameter	Press the MENU key for 1s to enter the setting mode when the icon  appears on the display interface, and exit automatically after 30s
Load On/Off	When the controller is working in street lamp mode, press the MENU key for 3s to turn on the load, press the MENU key again or 1min later the load will be off.

6.3 USB interface

MT1050-EU series have two USB interfaces, maximum output of single USB is 5V 1.5A, maximum output of two USB is 5V 2A, for charging mobile phones and other smart devices.

The USB stops output only when the controller is in low voltage protection.

6.4 Parameters setting

When the icon  appears in the display interface, it means that the parameters can be set. Long press the **MENU** key for 1s, then icon  flashes, press **OK** to change the parameter.

6.4.1 Low voltage protection and reconnect

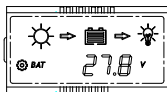

When the LCD shows as the left, press the **MENU** key for 1s, the icon  flashes, you can set the controller's low voltage protection, low voltage protection is divided into battery voltage control and SOC.

① Battery voltage control

Low voltage protection setting range: 10.8~11.8V/21.6~23.6V.
Low voltage reconnect range: 11.6~12.6V/23.2~25.2V.

② SOC

Display	Low voltage protection range	Low voltage reconnect
S-1	11.0~11.6V/22.0~23.2V	12.4/24.8V
S-2	11.1~11.7V/22.2~23.4V	12.5/25.0V
S-3	11.2~11.8V/22.4~23.6V	12.6/25.2V
S-4	11.4~11.9V/22.8~23.8V	12.7/25.4V
S-5	11.6~12.0V/23.2~24.0V	12.8/25.6V

6.4.2 Battery type

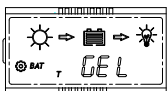

When the LCD shows as the left, press the **MENU** key for 1s, the icon  flashes, you can set battery type.

Display	Battery type
GEL	GEL
AG-	AGM
L19	Liquid

6.4.3 Load mode

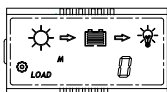

When the LCD shows as the left, press the **MENU** key for 1s, the icon  flashes, you can set the load mode.

Display	Load mode
0	Standard, 24H
1	Dusk to Dawn
23456789	Load will be on for 2~9hours since sunset
USE	User-defined mode



Test Function(Street lamp mode)

When the controller is working in the street lamp mode, press the **MENU** key for 3 seconds to turn on the load. Press the **MENU** key again or the load turns off automatically after 1 minute. If the controller is operating in 24H output mode, the test function does not work.



User-defined mode

When the controller is set to user-defined mode, the load is turned on by default. Short press the **MENU** key, the load will be turned off, press the **MENU** key again, the load will be turned on.

Note:

1.If the controller turns off the load due to low voltage protection, overcurrent protection, short-circuit protection or over temperature protection, the load will turn on automatically when the controller recovers from protection state.,.

2.Please note: Pushing the MENU button can still activate the function of the key, even during of the above four kinds protection states.

7, Protections, Troubleshooting and maintenance

7.1 Protection

■ PV Over Current

The controller will limit charging power in rated charge power. An over-sized PV array will not operate at maximum power point.

■ PV Short Circuit

When PV short circuit occurs, the controller will stop charging. Remove it to start normal operation.

■ PV Reverse Polarity

Fully protection against PV reverse polarity, no damage to the controller. Correct the connection to start normal operation.

■ Battery Reverse Polarity

Fully protection against battery reverse polarity, no damage to the controller. Correct the connection to start normal operation.

■ Battery Over voltage

If there are other energy sources to charge the battery, when the battery voltage exceeds 15.5 / 31.0V, the controller will stop charging to protect the battery from overcharging damage.

■ Battery Over discharge

When battery voltage drops to the setting voltage point of Low Voltage Disconnect , the controller will stop discharging to protect the battery from over discharging damage.

■ Load Over Current Protection

If the load current exceeds the maximum load current rating 1.25 times, the controller will disconnect the load.

■ Load Short Circuit Protection

Once the load short circuit happens , the load short circuit protection will start automatically.





■ Over Temperature Protection

The controller detects the internal temperature through internal sensor, when the temperature exceeds the setting value, the charging current will lower down followed by the decrease of temperature, so as to control the controller' s temperature rise; when the internal temperature exceeds the setting value, the controller stops working and restores after the temperature is lowered

■ Damaged Remote Temperature Sensor

If the temperature sensor is short-circuited or damaged, the controller will be charging or discharging at the default temperature 25°C to prevent the battery damaged from overcharging or over discharged.

7.2 Troubleshooting

Faults	Reason	Troubleshooting
 E1	Short Circuit	Switch off all loads, remove short circuit, load will be reconnected after 1 minute automatically
 E2	Over Current	Reduce the load, the controller will resume to work after 1minute.
 E3	Battery voltage is too low	Load will be reconnected when battery is recharged
 E4	Battery voltage is too high	Check if other sources overcharge the battery. If not, controller is damaged.
 E5	Over temperature	After the temperature decreases, the controller will work normally
Wire connection is correct, LCD not display	Battery voltage is abnormal at start-up	Charge or discharge the battery so that the battery voltage is within the normal operating range(10~15V or 20~30V)
Battery can't be charged during daytime	PV panel fault or reverse connection	Check panels and connection wires

7.3 Maintenance

The following inspections and maintenance tasks are recommended at least two times per year for best performance.

- Make sure no block on air-flow around the controller. Clear up any dirt and fragments on radiator.
- Check all the naked wires to make sure insulation is not damaged. Repair or replace some wires if necessary.
- Tighten all the terminals. Inspect for loose, broken, or burnt wire connections.
- Check and confirm that LCD is consistent with required. Pay attention to any troubleshooting or error indication .Take corrective action if necessary.
- Confirm that all the system components are ground connected tightly and correctly.
- Confirm that all the terminals have no corrosion, insulation damaged, high temperature or burnt/discolored sign, tighten terminal screws to the suggested torque.
- Check for dirt, nesting insects and corrosion. If so, clear up in time.



WARNING: Risk of electric shock!

Make sure that all the power is turned off before above operations, and then follow the corresponding inspections and operations.

8, Technical Data

8.1 Technical data of MT1050/1550-EU/MT2075/MT3075

	Item	MT1050EU	MT1550EU	MT2075	MT3075
Battery Parameters	System Voltage	12V		12/24V auto	
	Max Charging Current	10A	15A	20A	30A
	MPPT Charging Voltage	< 14.5V@25°C			
	Boost Voltage	14.5V@25°C		14.5/29.0V @25°C	
	Equalization Voltage	14.8V@25°C		14.8/29.6V @25°C (Liquid)	
	Floate Voltage	13.7V@25°C		13.7/27.4V @25°C	
	Low Volt. Disconnect	10.8~11.8V, SOC1~5		10.8~11.8/21.6~23.6V, SOC1~5	
	Reconnect Voltage	11.6~12.8V		11.6~12.8V/23.2~25.6V	
	Overcharge Protect	15.5V		15.5/31.0V	
	Max volt on Bat. terminal	20V		35V	
	Temp. Compensation	-4.17mV/K per cell (Boost, Equalization), -3.33mV/K per cell (Floate)			
	Battery Type	Gel, AGM, Liquid			
Panel Parameters	Max volt on PV terminal	45V	35V	55V	*1
	Max input power	130W	200W	260/520W	390/780W
	Dusk/Dawn detect volt.	8.0V		8.0/16.0V	
	MPPT tracking range	(Battery Voltage + 1.0V) ~ Voc*0.9 *2			
Load	Output Current	10A		20A	30A
	USB interface	5V, 2A		—	
	Work mode	Standard, D2D, Street lamp, User-defined mode			
System Parameters	Max tracking efficiency	>99.9%			
	Max charge conversion	97.5%		98.0%	
	Dimensions(mm)	189 * 96 * 53		189 * 182 * 58	189 * 182 * 64
	Weight	420g		1Kg	1.3Kg
	Self consumption	7mA			
	Ambient temperature	-20 ~ +55°C			
	Storage temperature	-25 ~ +80°C			
	Ambient humidity	0 ~ 100%RH			
	Protection degree	IP32			
Max Altitude	4000m				

*1.This value represents the maximum voltage of the solar panel at the minimum operating ambient temperature.

*2.Voc means the open circuit voltage of the solar panel.

*3.Around oblique line value separately on behalf of 12V and 24V system's value.

8.2 Technical data of MT2010/MT3010/MT4010

	Item	MT2010	MT3010	MT4010
Battery Parameters	Max Charging Current	20A	30A	40A
	System Voltage	12V/24V automatical recognition		
	MPPT Charging Voltage	<14.5/29.0V@25°C		
	Boost Voltage	14.5/29.0V @25°C		
	Equalization Voltage	14.8/29.6V @25°C (Liquid)		
	Float Voltage	13.7/27.4V @25°C		
	Low Volt. Disconnect	10.8~11.8V/21.6~23.6V, SOC1~5		
	Reconnect Voltage	11.6~12.8V/23.2~25.6V		
	Overcharge Protect	15.5/31.0V		
	Max volt on Bat. terminal	35V		
	Temp. Compensation	-4.17mV/K per cell (Boost, Equalization), -3.33mV/K per cell (Float)		
Battery Type	Gel, AGM, Liquid			
Panel Parameters	Max volt on PV terminal	100V *1		
	Max input power	260/520W	390/780W	520/1040W
	Dusk/Dawn detect volt.	8.0/16.0V		
	MPPT tracking range	(Battery Voltage + 1.0V) ~Voc*0.9 *2		
Load	Output Current	20A	30A	
	Work mode	Standard, D2D, Street lamp, User-defined mode		
System Parameters	Max tracking efficiency	>99.9%		
	Max charge conversion	98.0%		
	Dimensions(mm)	189 * 182 * 64	189 * 255 * 69	
	Weight	1.3Kg	2Kg	
	Self consumption	7mA		
	Ambient temperature	-20 ~ +55°C		
	Storage temperature	-25 ~ +80°C		
	Ambient humidity	0 ~ 100%RH		
	Protection degree	IP32		
Max Altitude	4000m			

*1.This value represents the maximum voltage of the solar panel at the minimum operating ambient temperature.

*2.Voc means the open circuit voltage of the solar panel.

*3.Around oblique line value separately on behalf of 12V and 24V system's value.